



**Scaleton™
Sets The Standard
In Corrosion
Resistance**

Model 2305D™ Economical Digital Dual Cylinder Scale

- Designed for weighing 10-1/2" diameter cylinders
- Two independent weighing bases and digital LCD displays
- Base size: 12-5/8"x14-3/4"
- Gross capacity range: 0-300 lbs. (0-136 kg)
- High accuracy of $\pm 0.5\%$ of capacity
- Standard indicator: 3-1/2 digit LCD display with easy readability to 1 lb. (kg) or 0.1 lb. (kg)
- Readout in pounds or kilograms
- Simple one load cell design



Dual 3-1/2 Digit Indicator
(Standard)



1020™ 5 Digit
Controller (Optional)



1099™ Chemical
Process Controller
(Optional)



Standard Features

- Rugged steel construction protected by a corrosion resistant finish, with solid 1/8" PVC decking for use in harsh environments
- Low profile platform design increases safety and ease of cylinder handling
- Electronic indicator housed in NEMA 4X, UL approved enclosure to provide protection from acids
- Stainless steel load cell
- Self-locking tare adjustment knob
- 4-20 mA output signal – scale or loop powered
- 12 ft. of 4 conductor wire cable
- Cylinder support with tool rack and chains

Options

- Battery operated version with rechargeable battery pack
- Low level relay contacts
- Model 1020 5 Digit Controller with loop powered 4-20 mA, up to four adjustable set points and one or two channels
- Model 1099 Chemical Process Controller
- Remote mounting of indicator box up to 200 feet (61 meters) away
- Junction box - Additional length of wire cable

Chemicals

Scale is designed to accurately measure weight of alum, ammonia, caustic, fluoride, phosphate, polymers, sodium aluminate, sodium bisulfate, sodium hydroxide, sodium hypochlorite and other liquids or powders

Scaleton Industries Ltd.

Bedminster Industrial Park
53 Apple Tree Lane • P.O. Box 365
Plumsteadville, PA 18949 • USA

Tel: (+1) 215-766-2670 (International)
Tel: (+1) 800-257-5911 (USA & Canada)
Fax: (+1) 215-766-2672

Email: info@scaletonscales.com
Website: www.scaletonscales.com

Model 2305D™ Economical Digital Dual Cylinder Scale

General Specifications

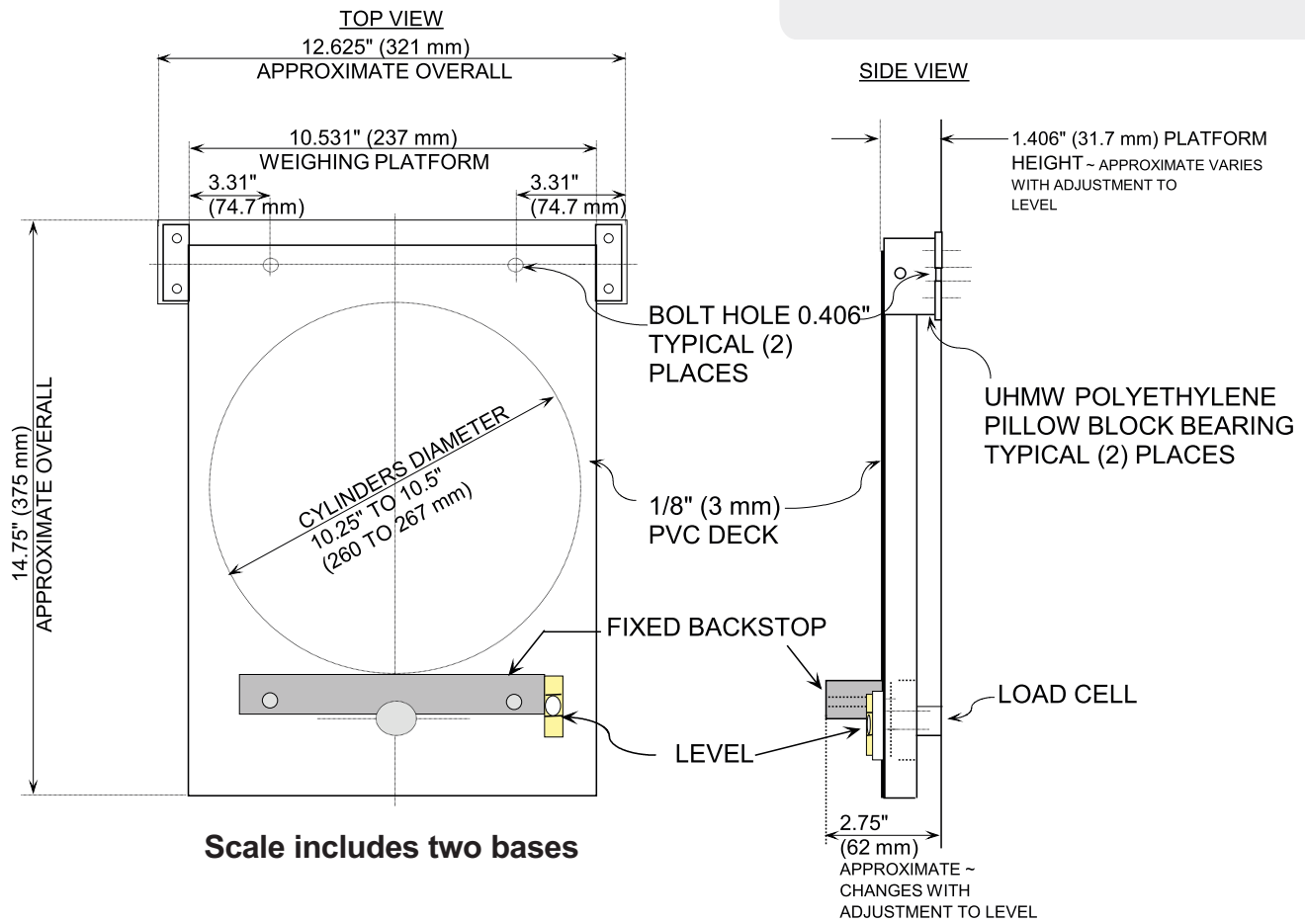

Indicator:	Dual 3-1/2 Digit
Platform Size:	12-5/8" (321 mm) wide x 14-3/4" (375 mm) deep each – custom sizes available
Platform Height:	1.4" (35.6 mm)
Gross Capacity:	0 to 300 lbs. (0 to 136 kg) – custom capacities available
Accuracy:	±0.5% of full capacity
Resolution:	0.1 lb. (kg) up to 199.9 lbs. (kg)
4-20 mA:	Standard – scale or loop powered
Level Indication/ Relay Contacts:	Optional low level REED relay contact(s)
Power:	85 VAC to 265 VAC, 50/60 Hz
Enclosure:	NEMA 4X, UL Approved Enclosure
Shipping Weight:	23 lbs.

Typical Specifications

The Economical Digital Dual Cylinder Scale must weigh two 150 lb. cylinders. The base must be zinc oxide primed and dry powder epoxy coated steel with PVC decking to prevent corrosion. All base hardware must be stainless steel. There must be a provision for securing weigh frame to floor. The height shall not exceed 1.4 inches (36 mm) so as not to require a pit or ramp. The load cell must be NTEP approved, stainless steel shear beam cell. Cylinders shall be centered and placed against backstop. Base must be fully electronic with no mechanical lever system to corrode.

Scale shall be a Model 2305D™ as manufactured by Scaleton Industries Ltd., Plumsteadville, PA.

CE 5 year **FULL warranty** on **ALL products!**

OPTIONAL CONTROLLERS:

Model 1020™ 5 Digit LCD Controller: Indicator must be electronic with a two line, backlit alphanumeric digital display with characters 0.56 inches high and housed in a NEMA 4X, UL approved enclosure. Available as single or dual channel and capable of displaying two channels simultaneously. A loop powered programmable output of 4-20 mA and two set points per channel must be standard equipment. Indicator must be capable of 0.1 lb. or 0.1 kg up to 9999.0 lbs. or kg. Accuracy is 0.5% of full scale, or better.

Model 1099™ Chemical Process Controller see separate specification.